

model : Solar street lamp 60W

Appearance drawing

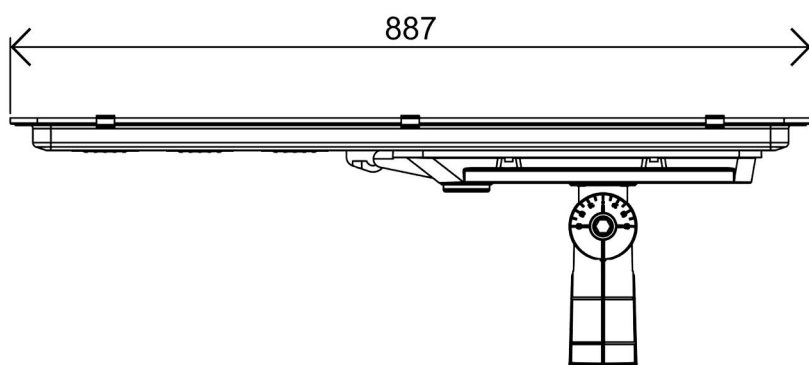

Line drawing



Main view

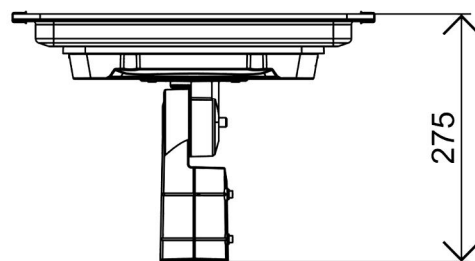

Left view

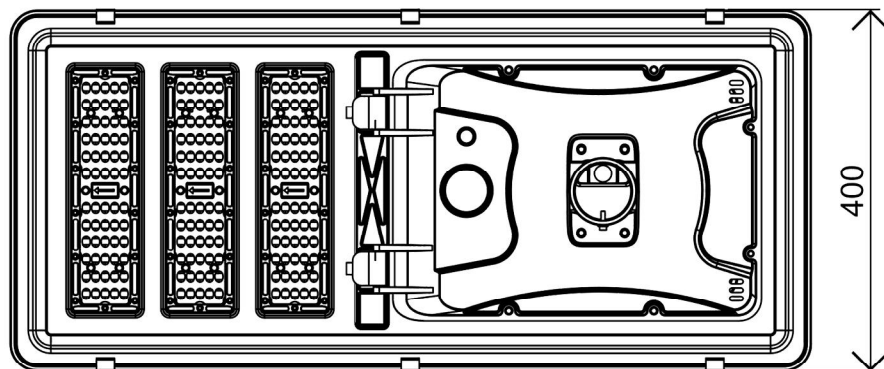

vertical view

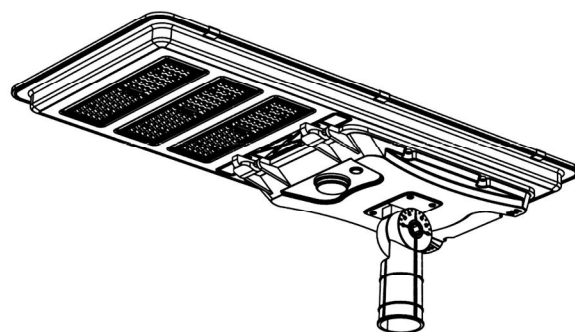

Perspective view

Aluminum substrate lens

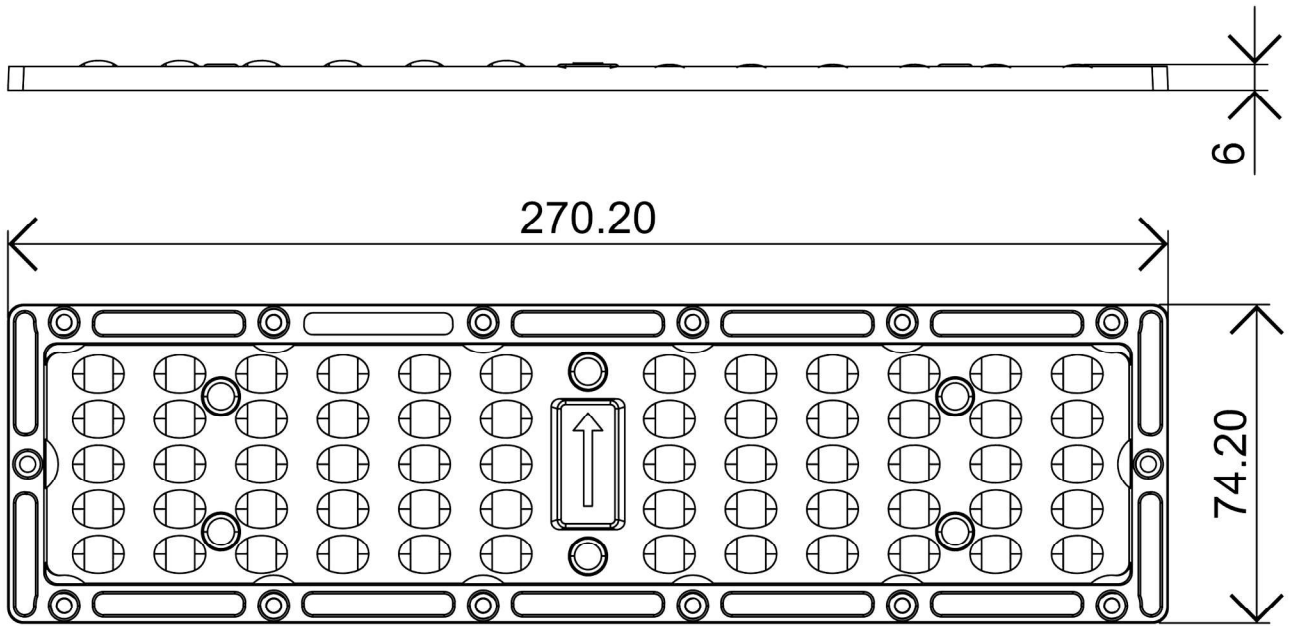

lens:L270*W74*6 60PCS 70°*140°

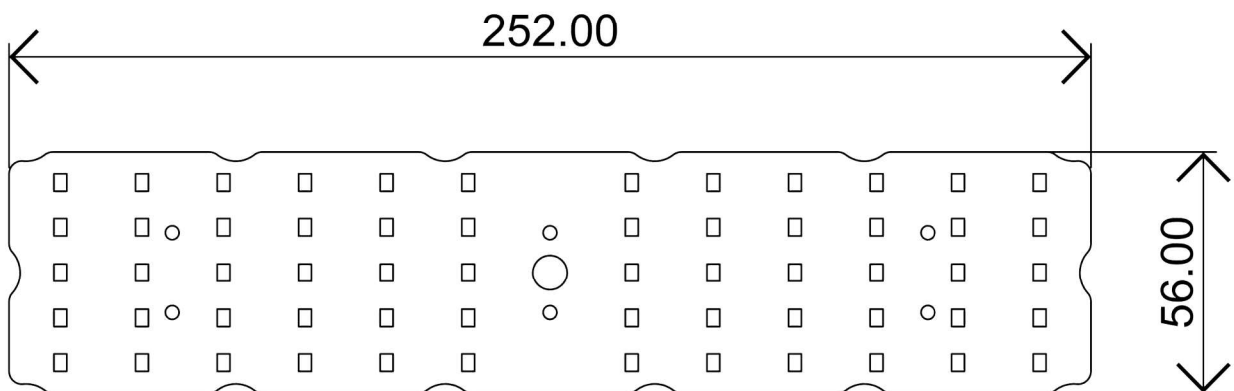

PCB: W56*L252*1.2 10P6S/60P1S 3030

Size hole location

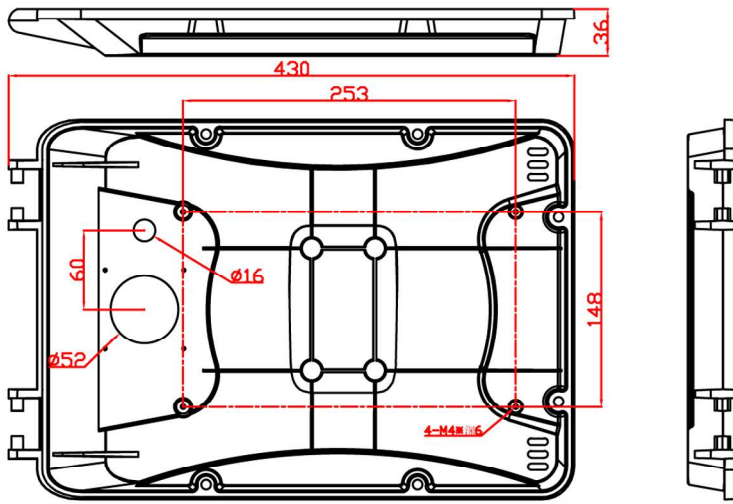

注：这次样板做4-M10*深6.5
大货孔钻成4-M8*深6.5

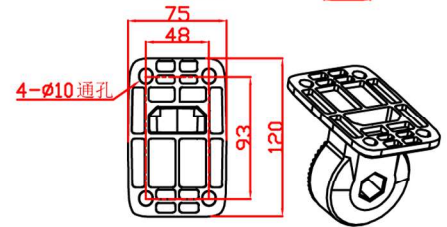
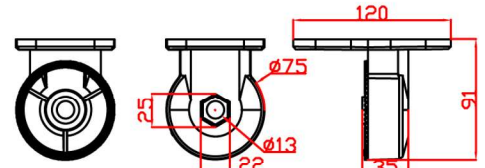
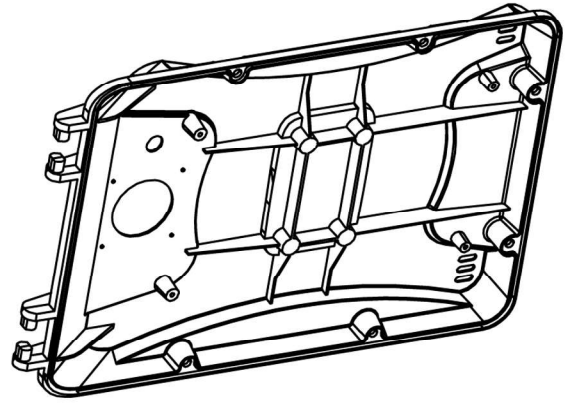
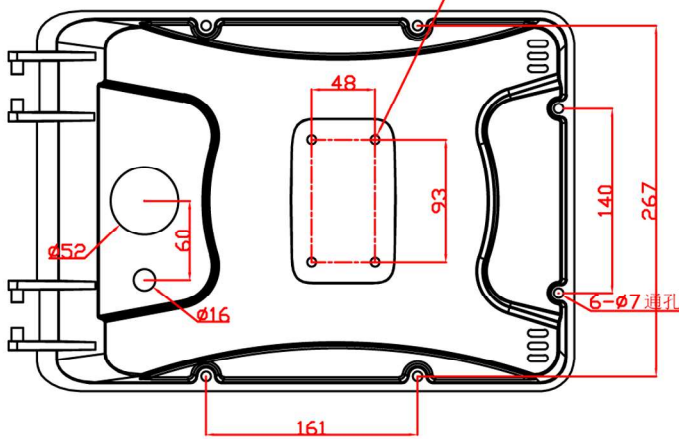

Weight of aluminum alloy installation pipe 274G

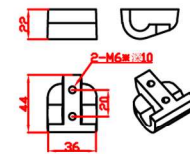

Weight of aluminum alloy lamp body 945G

Aluminum alloy buckle weight 46G

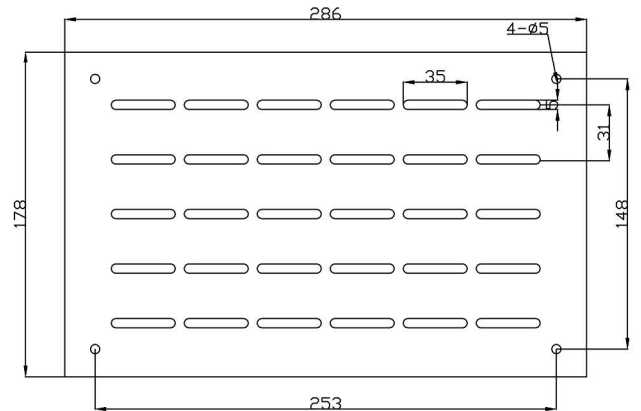
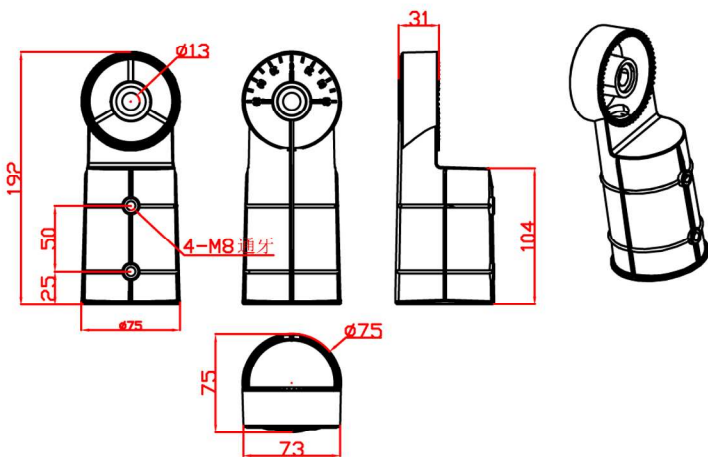

Aluminum handle weight 323G

Battery fixing plate

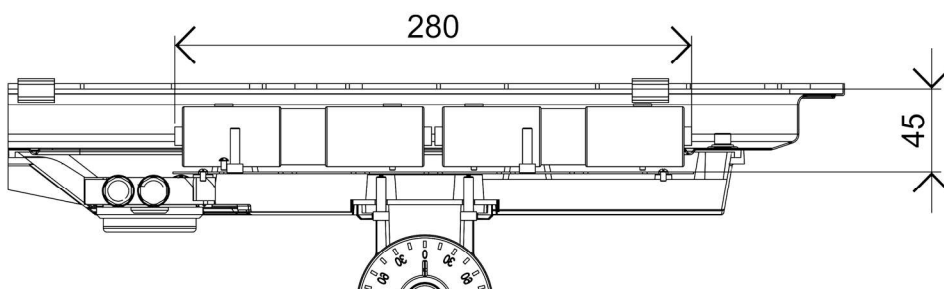

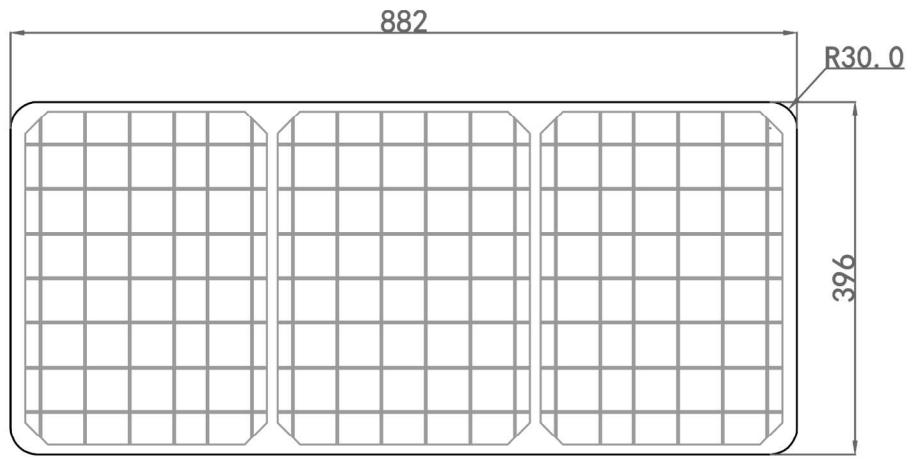

PV panel size T4.0

Explosion diagram

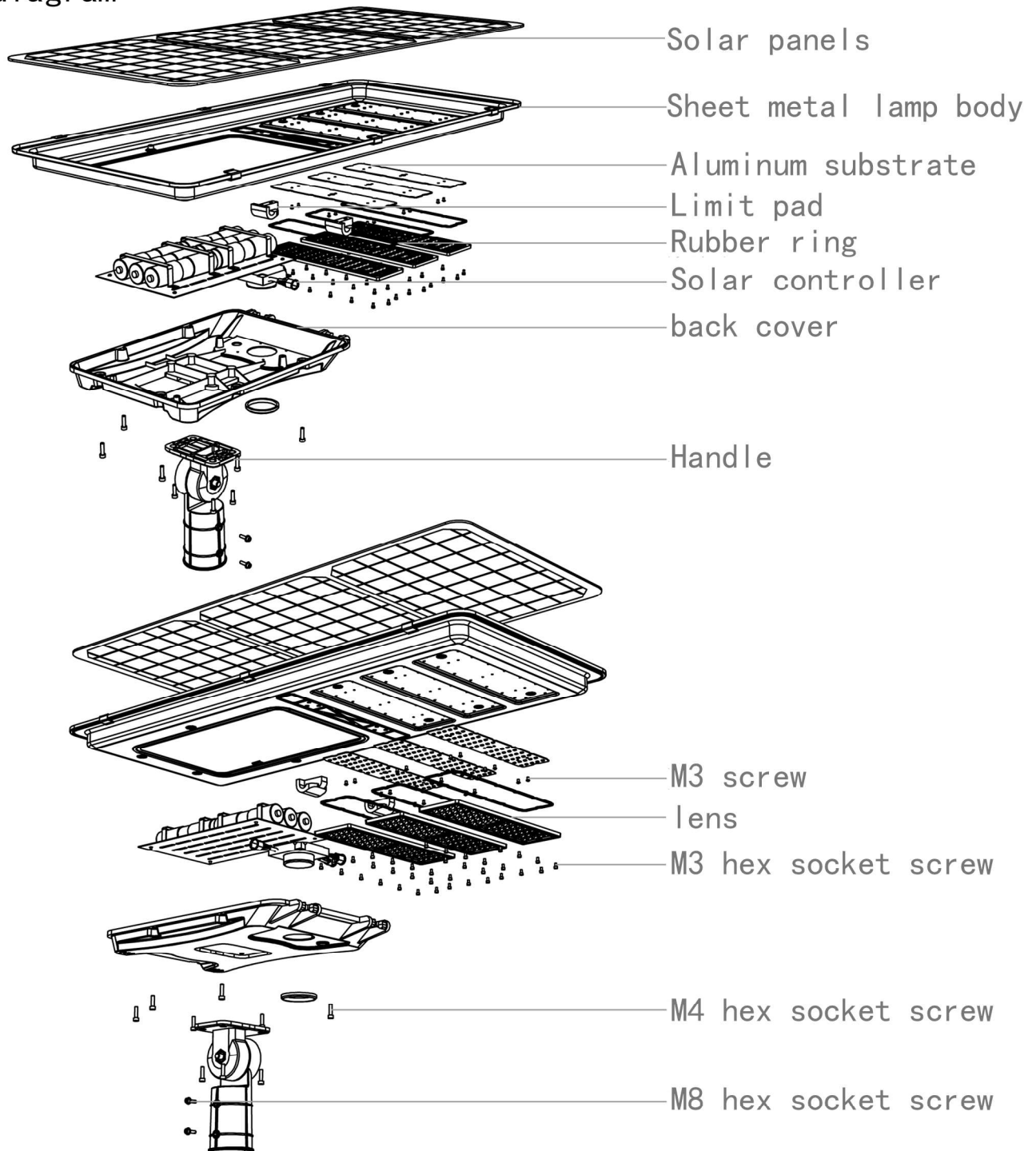

Package size:

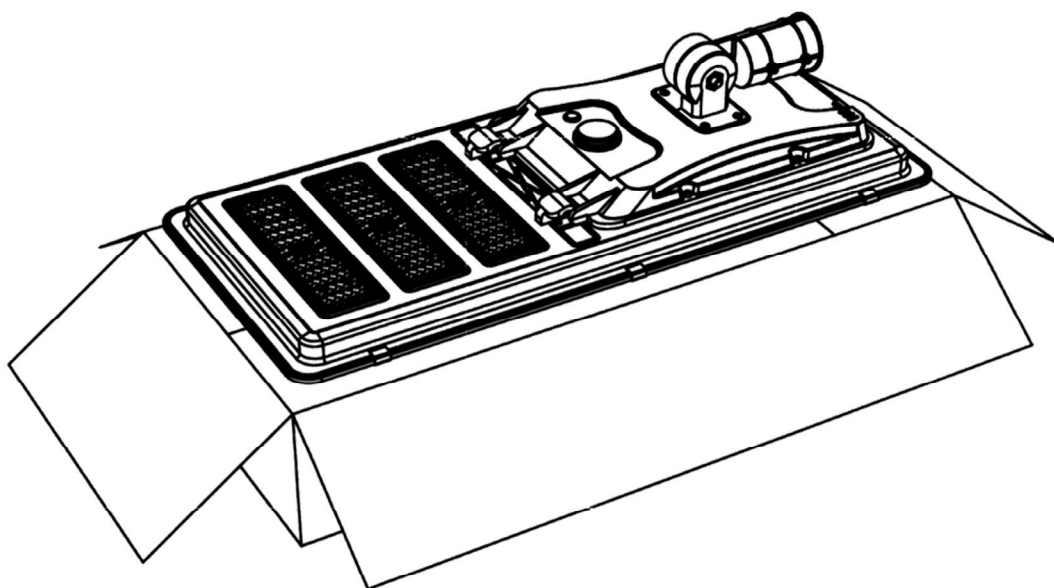
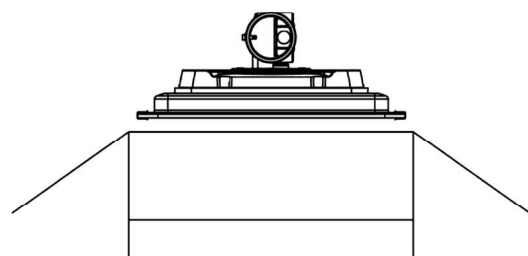
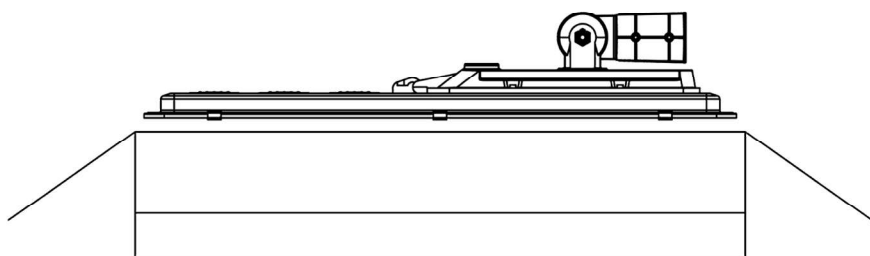
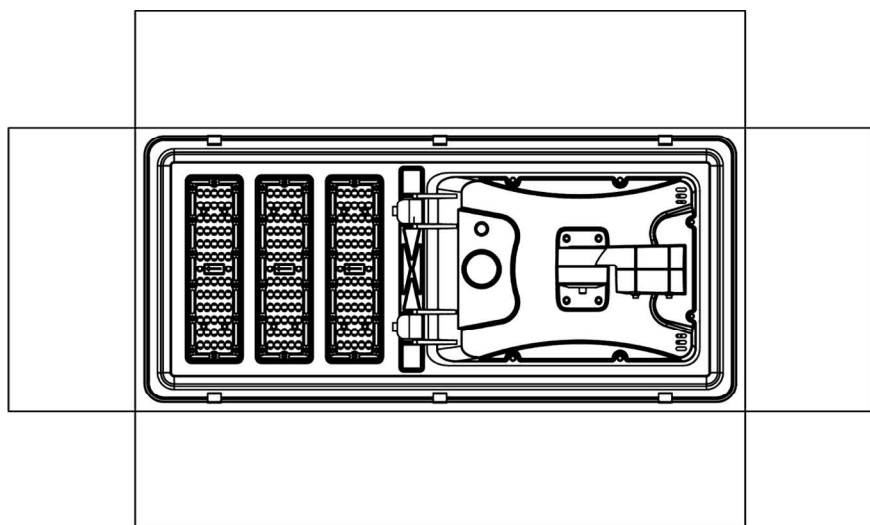

Outer box size: 1035mm*450mm*115mm
